

CONTINUED SHEET 1

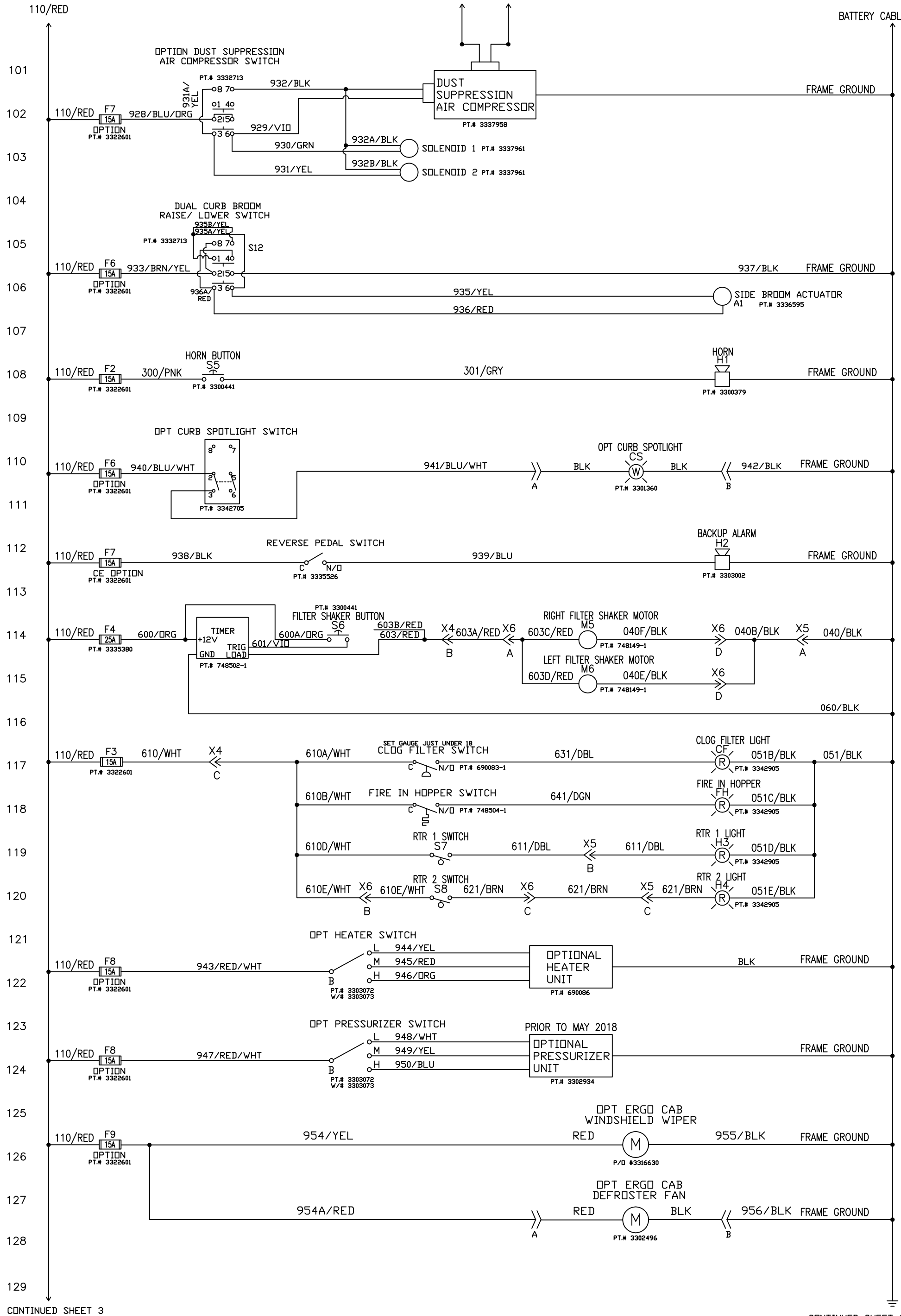

CONTINUED SHEET 3

CONTINUED SHEET 3

REV	ECN	DATE	DESCRIPTION	BY	PowerBoss® The Power of Clean		CONFIDENTIAL THIS DRAWING AND ALL INFORMATION CONTAINED HEREIN ARE THE EXCLUSIVE PROPERTY OF MINUTEMAN INTERNATIONAL, INC. THIS DRAWING IS NOT TO BE COPIED OR OTHERWISE REPRODUCED WITHOUT EXPRESSED WRITTEN PERMISSION OF MINUTEMAN INTERNATIONAL, INC. IN ADDITION, THIS DRAWING MUST BE RETURNED UPON REQUEST. FURTHER, ALL INFORMATION CONTAINED HEREIN MUST BE MAINTAINED CONFIDENTIAL.	TITLE	PART NUMBER	REVISION	PAGE NUMBER
D	MIN-13437	03/09/17	UPDATED DIESEL SCHEMATIC, SHEET 1 & 4	KHH	14N845 U.S. ROUTE 20 PINGREE GROVE, ILLINOIS 60140		SCHEMATIC-ELECTRICAL AM9D/9X DIESEL CE	3397501	G	2 OF 5	
E	MIN-13574	10/02/17	ADDED BLUE SAFETY LIGHTS	KHH	ELECTRICAL DESIGN ENGINEER Jeff Pollack						
F	150297	06/11/18	ADDED GLOW PLUG LT, MERV, LED LIGHTS & SHT 5	KHH	CAD BY JWP						
G	150470	11/13/18	UPDATED MERV, PART #'S	KHH	DATE 5/3/10						